

PIPER SUPER CUB

**PRE-1974
95/150 hp.**

PA-18 and PA-18A OWNER'S MANUAL

PIPER SUPER CUB

**PRE-1974
95/150 hp.**

PA-18 and PA-18A OWNER'S MANUAL

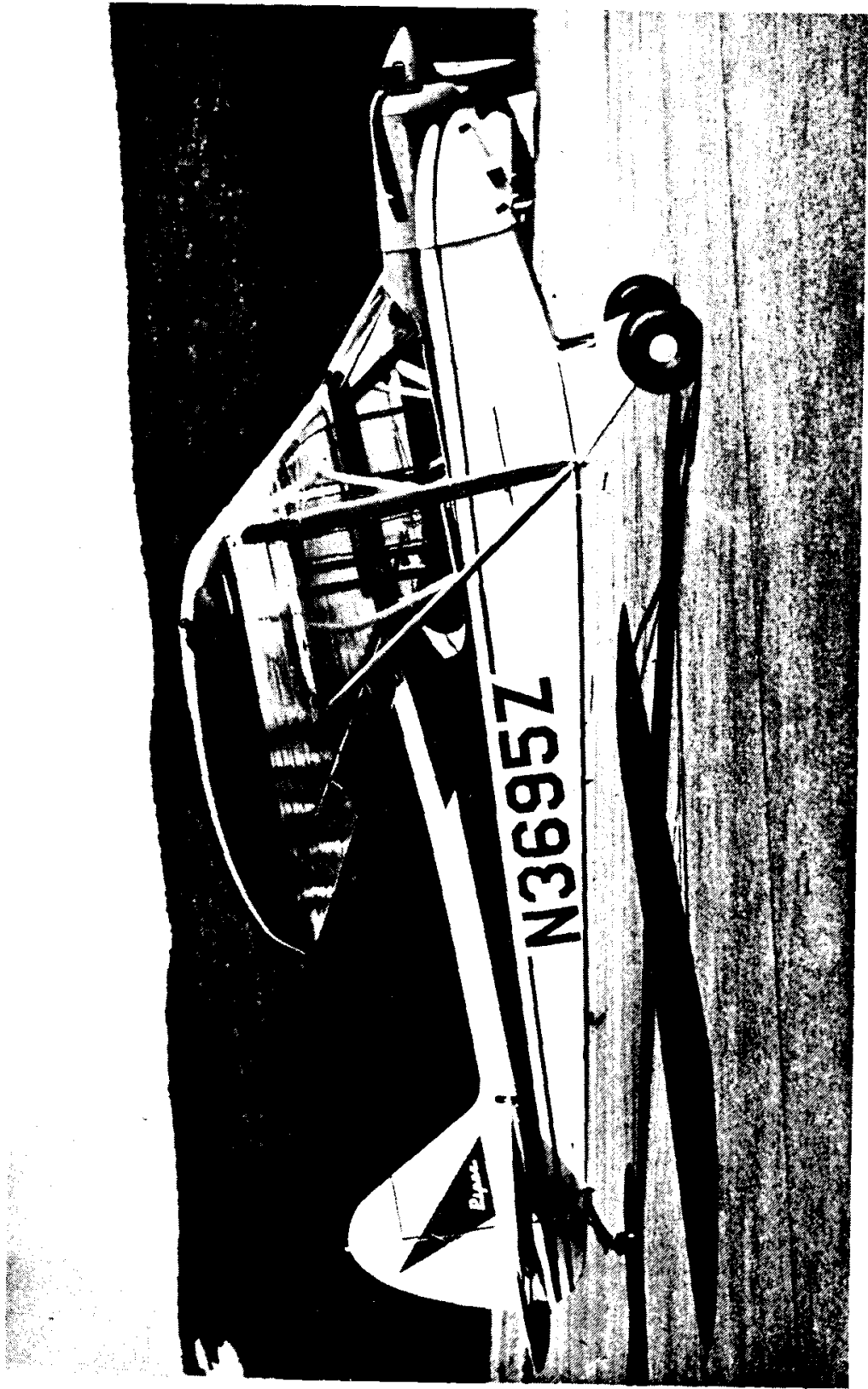

SECTION I

SPECIFICATION FEATURES

Power Plant	1
Performance Data	1
Weights	2
Fuel and Oil	3
Baggage	3
Dimensions	3
Landing Gear	3

SPECIFICATION FEATURES:

POWER PLANT	PA-18-95	PA-18-150
Engine	Cont. C-90	Lyc. O-320
Rated Horsepower	90	150
Rated Speed RPM	2475	2700
Bore, inches	4-1/16	5-1/8
Stroke, inches	3-7/8	3-7/8
Displacement, cubic inches	200.91	319.8
Compression Ratio	7:1	7:1
Fuel Consumption (75% power gph)	5	9
Oil Sump Capacity (qts.)	5	8
Fuel Aviation Grade Octane	80	80

PERFORMANCE	PA-18-95 Wood Prop	PA-18-95 Std. Metal Prop
Take-off Run (ft.)	452	390
Take-off Run over 50 ft. barrier	952	750
Best Rate of Climb Speed (MPH)	71	71
Rate of Climb (ft. per min.)	624	710
Best Angle of Climb Speed (MPH)	63.5	63.5
Best Angle of Climb (Ratio)	1 to 9.4	1 to 8
Service Ceiling	13,500	15,750
Absolute Ceiling	16,000	17,750
Top Speed	110	112
Cruising Speed (75% power MPH)	100	100
Cruising Range (75% power)	360	360
Fuel Consumption (gph) (75% power)	5	5
Stalling Speed (MPH)	42	42
Landing Roll (ft.)	385	385

SPECIFICATION FEATURES: (cont)

<u>PERFORMANCE</u>	<u>PA-18-150</u> Metal Prop 1750 lbs.
Take-off Run (ft.)	200**
Take-off Run over 50 ft. barrier	500**
Best Rate of Climb Speed (MPH)	75
Rate of Climb (ft. per min.)	960
Best Angle of Climb Speed (MPH)	45
Best Angle of Climb (Ratio)	1 to 5
Service Ceiling	19,000
Absolute Ceiling	21,300
Top Speed (MPH)	130
Cruising Speed (75% power MPH)	115
Cruising Range (75% power)	460
Fuel Consumption (gph) (75% power)	9
Stalling Speed (MPH)	43**
Landing Roll (ft.)	350*

**Flaps extended.

Performance figures are for airplanes flown at gross weight under standard conditions at sea level.

<u>WEIGHTS</u>	<u>PA-18-95</u>	<u>PA-18-150</u>
Gross Weights (lbs.)	1500	1750
Empty Weight (standard) (lbs)	800	930
USEFUL LOAD (lbs.)	700	820

SPECIFICATION FEATURES: (cont)

<u>FUEL AND OIL</u>	<u>PA-18-95</u>	<u>PA-18-150</u>
Fuel Capacity (gal.)	18	36
Oil Capacity (qts.)	5	8

BAGGAGE

Maximum Baggage (lbs.)	50	50
Baggage Space (cubic ft.)		

DIMENSIONS

Wing Span (ft.)	35.3	35.3
Wing Area (sq. ft.)	178.5	178.5
Wing Loading (lbs. per sq. ft.)	8.4	10
Length (ft.)	22.4	22.5
Height (ft.)	6.7	6.7
Power Loading (lbs. per HP)	16.6	11.6
Propeller Diameter (max. in.)	74	74

LANDING GEAR

Tire Pressure (psi)	18	18
Tire Size (four ply rating)	8:00 x 4	8:00 x 4

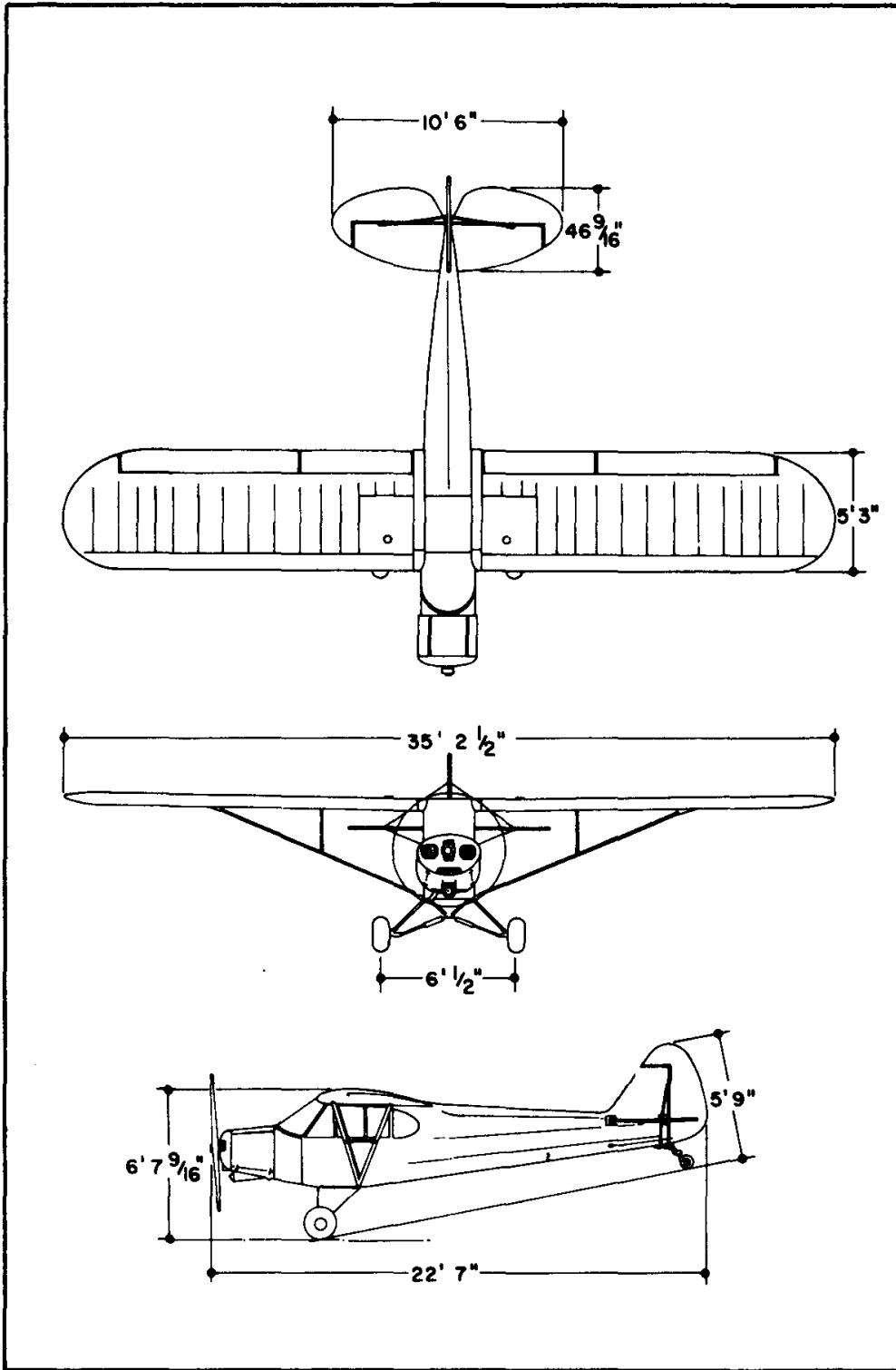

SECTION II

DESIGN INFORMATION

Engine and Propeller	5
Structures	6
Landing Gear	7
Control System	7
Fuel System	8
Electrical System	10
Finish	12
Cabin Features	12

SECTION II

DESIGN INFORMATION

ENGINE AND PROPELLER

The Super Cub 95 is powered with a Continental C-90-8F engine or a C-90-12F if starter and generator (optional equipment) are installed. These engines are rated at 90 H.P. at 2475 R.P.M.

The Super Cub 150 is powered with a Lycoming O-320 engine, with a rated horsepower of 150 at 2700 R.P.M. The standard installation of this engine is also without electrical system, which is available optionally.

The steel tubular engine mount on the Super Cub models is mounted to the fuselage at the firewall on hinges, so that the rear of the engine can readily be made accessible for service. To hinge the motor mount, first remove the top, side and bottom engine cowl panels, which are quickly detachable by means of cowl fasteners. Next detach the rear end of the cowl support channels from their firewall brackets, extract the right hand hinge bolts, disconnect the tachometer shaft at the engine and swing the right side of the engine forward until the stop mechanism is extended.

The standard propeller on the Super Cub 95 is the Sensenich wood propeller design 72-GK-50. A Sensenich metal propeller design M-76AK-2 is available as optional equipment. On the 150, the standard propeller is the Sensenich metal design 74-DM-56. In general, propeller designs selected for the Super Cub models emphasize take-off, climb and economical



cruising performance rather than high speed cruising. If propellers with higher pitches are used, the cruising speed can be increased somewhat.

A stainless steel cross-over exhaust system is employed on the "150" to scavenge exhaust gases effectively. This permits the use of an efficient muffler without any loss in engine power output due to exhaust back-pressure. The muffler is shrouded to provide sources of heat for the cabin and carburetor heating systems.

STRUCTURES

The fuselage frame of the Super Cub is constructed of steel tubes welded together to form a rigid structure. A number of highly stressed members are of chromemolybdenum steel (4130). Other members are of 1025 steel.

Repairs to the fuselage can be made in the manner approved by the FAA Advisory Circular 43.13-1, and repair facilities for this type of construction are available universally.

The fuselage is made corrosion resistant by the application of a coat of zinc chromate, followed by a sealer coat of nitrate dope. A third coat of dope proof lacquer is sprayed on the fuselage members wherever fabric comes in contact with the structure. If the airplane is to be used in salt water areas, the fuselage can be metalized prior to applying the zinc chromate and dope; at the same time the interior of the tubing is coated with linseed oil to prevent internal corrosion.

The wing framework consists of riveted aluminum ribs mounted on extruded aluminum spars with tubular drag and compression struts and high strength stainless steel drag wires. Aluminum sheet is used to form the leading edge and the aileron false spar. An ash wing tip bow provides a light tough member which can withstand considerable wing tip shock without failing.

The wings are attached to the fuselage at the wing hinge fittings on upper fuselage members, and by means of the lift struts which bolt to the lower fuselage members and to the wing spar fittings. The lift struts can be adjusted in length

by turning in or out the forked fittings at the lower ends. This adjustment is used to set the rigging of the wings. To prevent bending the struts, any lifting of the airplane should be done at the extreme end of the strut and not in the center.

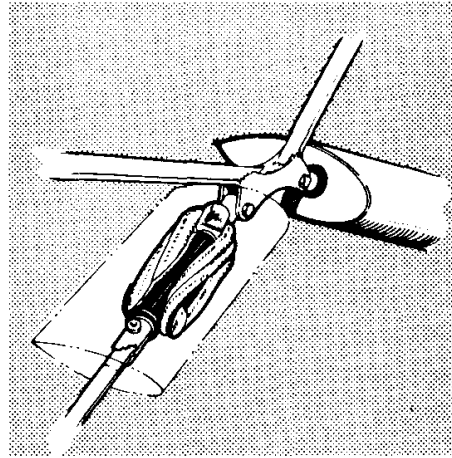

LANDING GEAR

The Super Cub landing gear is the well proven maintenance-free-shock cord type, which employs two 8" x 3/4" shock rings on each shock strut. The only maintenance required on this gear is occasional greasing of the hinge bolts and shock strut members, and inspection of the steel hinge bolt bushings, which can be replaced if worn.

Hydrosorb shock units, which consist of automotive type oleo struts combined with light shock cords, are available optionally.

The Scott steerable full-swivel tail wheel is provided as standard equipment on the Super Cub. The Maule steerable tail wheel, Model SFS-1-4 is offered as optional equipment.

Main wheel assemblies are Goodrich D-3-13-A-1, on which are mounted 8:00 x 4 four ply tires. The tire inflation of 18 lbs. must be maintained reasonably consistent to prevent tire slippage on the wheel and to produce even wear.

CONTROL SYSTEMS

The units which make up the empennage are the fin, rudder, stabilizers and elevators. They are all constructed of tubular steel with steel channel ribs. The control surface hinges have bronze bushing inserts and should be oiled with light oil occasionally. Stainless steel tie rods brace the stabilizer to the fin and fuselage. The tail brace wires should not be used for lifting or handling the airplane.

Although the fin and rudder are identical on both models of the Super Cub, the stabilizers and elevators are different in that the Super Cub 150 has a larger span on the tail surfaces to provide extra longitudinal stability, and the elevators are designed with an aerodynamic balance to increase stability and reduce control forces. On the Super Cub 95 the tail surfaces are almost identical with those of preceding tandem models.

Conventional dual flight and engine controls are provided in the Super Cub. In the model 150, which is equipped with flaps, the flap control is located for front seat operation only. Solo operation of both models is normally from the front seat although rear seat operation is entirely feasible.

The flap lever can be set in any one of three positions, for full up flap, half flap, or full down flap. Full flap is recommended for minimum speed landings. Half or full flap can be applied to reduce take-off run, the more flap used the shorter the run. A minimum take-off distance is obtained by beginning the take-off with flaps up, then applying full flaps when take-off speed (30-35 M.P.H.) has been reached. The best angle of climb is attained with full flap. The best rate of climb is without any flap extended.

The stabilizer adjustment crank is located on the left cabin panel adjacent to the front seat. A permanently automatic tension adjustment, which consists of an idler pulley held in place near the rear main pulley by a tension spring, maintains correct tension on the stabilizer cable and prevents cable slippage. This system normally requires no attention except for lubrication and inspection. Do not lubricate cables.

FUEL SYSTEM

An 18 gallon fuel tank located in the left wing is the main fuel supply for the Super Cub 95 in the standard installation. A second 18 gallon tank can be installed as optional equipment in the right wing. On the model 150, two 18 gallon tanks are standard equipment.

A small (approximately 2 quarts) header tank which serves to maintain constant fuel flow to the engine regardless of the

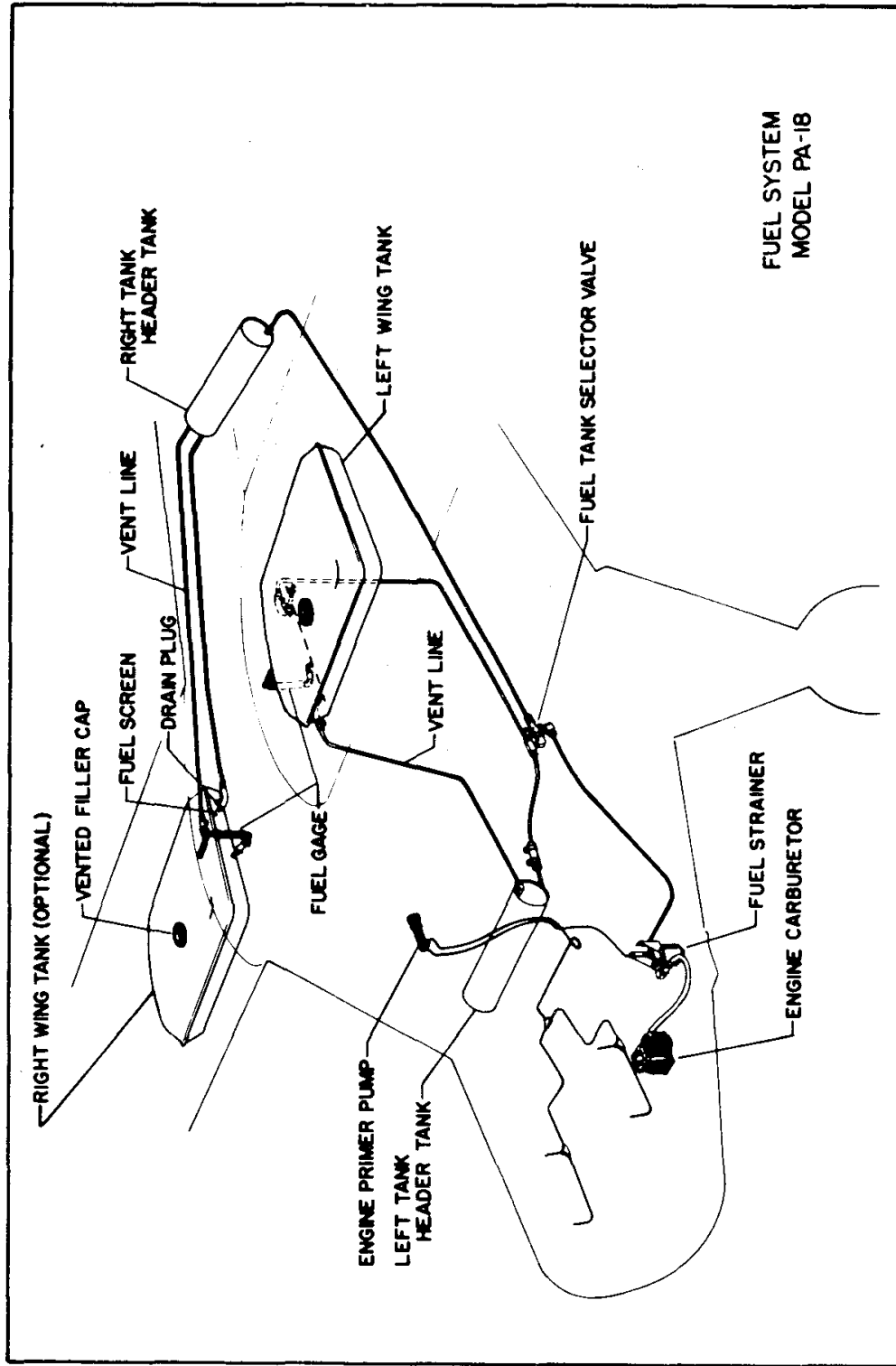

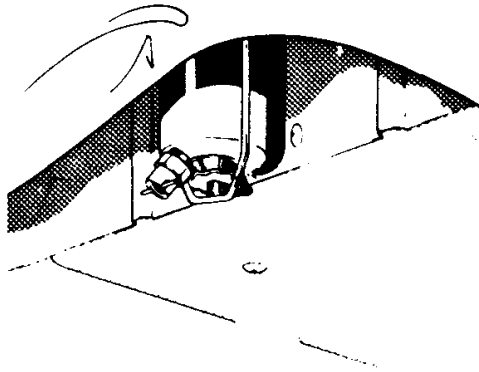

attitude of the airplane, is included in the installation of each fuel tank. The header tank for the left or main fuel tank is located forward of the instrument panel, for the right tank it is concealed behind the headlining aft of the rear seat.

Fuel indicator gauges are installed in the upper cabin panels and are easily discernible from either seat.

The fuel shut-off valve is in the left cabin panel near the front seat.

The fuel strainer, on the lower left side of the firewall in the engine compartment, traps water or sediment that may collect in the fuel system and should be checked regularly. Fuel screens are provided at each tank outlet, in the strainer, and at the carburetor.

The engine primer pump on the right side of the instrument panel takes fuel from the top of the fuel strainer and pumps directly to all four cylinders on the engine. The primer should be locked in at all times, except when in use, to prevent malfunctioning of the engine.

An idle cut-off is incorporated in the carburetor so that full extension of the mixture control stops the flow of fuel at the carburetor. The cut-off should always be used to stop the engine.

Use fuel alternately from the left and right tanks, about one hour each time, to maintain lateral trim.

ELECTRICAL SYSTEM

An electrical system, consisting of starter, generator,

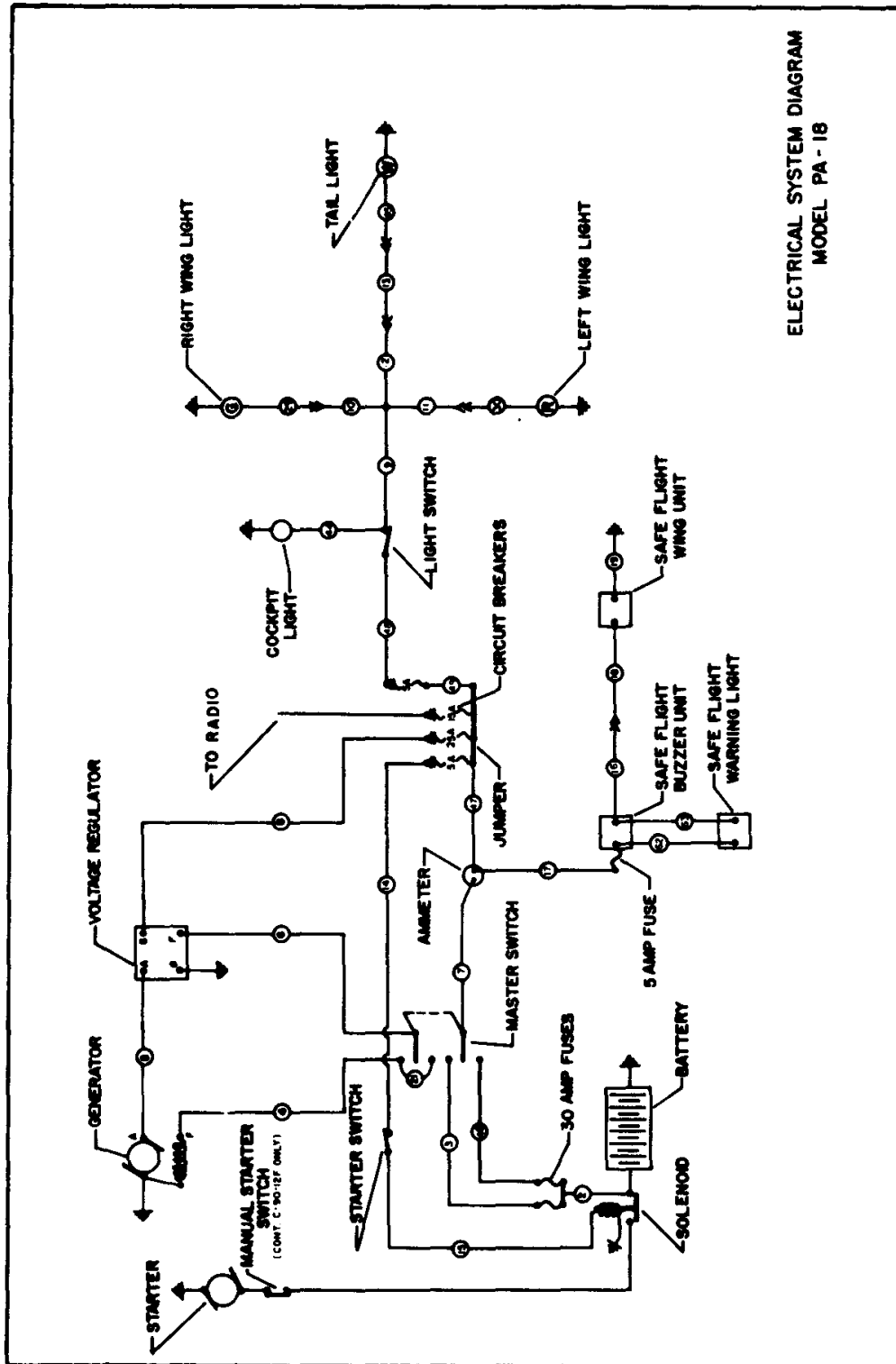

battery, voltage regulator, ammeter, starter solenoid, circuit breakers, fuses, switches and related wiring, is optional equipment on either model of the Super Cub.

A 12 volt battery is mounted in the fuselage aft of the baggage compartment. A master switch and circuit breakers are located on a panel over the right door. The circuit breakers automatically break the electrical circuits if an overload is applied. To reset the circuit breakers simply push in the buttons. A continuous popping of the circuit breakers indicates a short and should be investigated.

The master switch is connected with a main and a spare fuse, located near the battery box. The starter solenoid is also mounted near this box.

A voltage regulator attached to the engine side of the fire-wall is incorporated in the system to maintain the required voltage of the battery. Position and instrument panel lights (optional equipment) are operated with the same switch on the electrical panel.

FINISH

The Duraclad finish on the Super Cubs consists of fire resistant butyrate plastic material on the fabric surfaces, and enamel on metal surfaces. Duraclad provides, in addition to the fire resisting qualities, a high-luster, more attractive finish which has a much longer life than earlier nitrate finishes.

All of the fabric, inside and outside, on the new models is treated with butyrate plastic. All of the exterior metal surfaces are finished with enamel. The Duraclad finish must not be covered over with any incompatible material. The use of different materials from those originally applied will damage the finish.

CABIN FEATURES

The standard instrument group in the Super Cub includes the following: Altimeter, Airspeed, Compass, Oil Temperature and Pressure Gauge, and Tachometer. Special panels

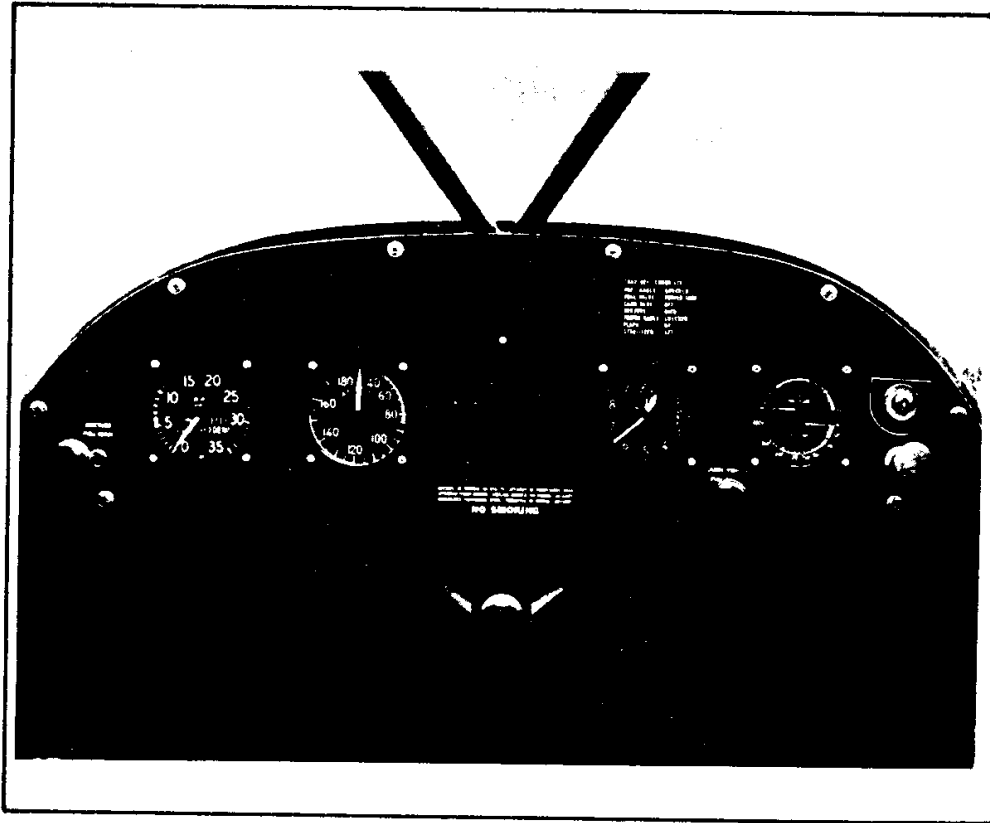

which provide complete instrumentation are available as optional equipment. A sensitive altimeter or recording tachometer is also available in the standard panel.

The front seat is adjusted fore and aft by lifting a lever on the left side of the seat frame. To remove the seat entirely, remove the forward stop pin on the left rear corner, then release the adjustment lever and slide the seat forward off its mounting channels.

To increase the space available for cargo carrying, the rear seat back can be easily removed. First pull out the spring

clips at the top of and behind the seat back, which hold the seat back in place. Then lift the back out of its lower sockets.

Shoulder harness kits are available for both seats of the Super Cub.

The control of the flow of hot air for heating the cabin is obtained through the use of the cabin heat control in the left side panel control box. Cooling air is admitted through the sliding windows on the left side of the cabin. For special purpose flights, such as photography, hunting, etc., the right door and window can be opened in flight, but care should be taken not to impose high air loads on the window in the open position.

SECTION III

OPERATING INSTRUCTIONS

Preflight	15
Starting	16
Warm-up and Ground Check	17
Take-off, Climb and Stalls	17
Cruising	17
Approach and Landing	19
Weight and Balance	19

SECTION III

OPERATING INSTRUCTIONS

PREFLIGHT

The following safety procedure instructions must become an integral part of the aircraft owner's operational routine and preflight inspection.

Before each flight visually inspect the airplane and determine that:

1. a. Ignition and battery switches "OFF".
2. a. There is no external damage or operational interference to the control surfaces, wings, or fuselage.
b. There is no snow, ice, or frost on the wings or control surfaces.
3. a. The fuel supply is checked and caps secured.
4. a. The tires are satisfactorily inflated and not excessively worn.

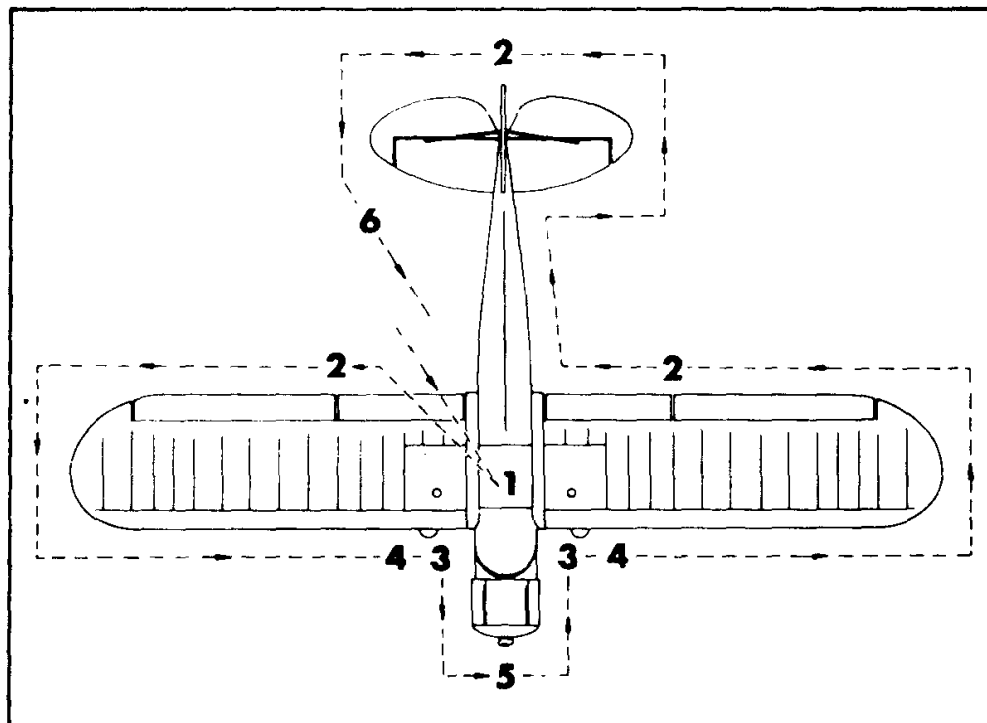

5. a. The cowling and inspection covers are secured.
- b. The windshield is clean and free of defects.
- c. The propeller is free of detrimental nicks.
- d. There are no obvious fuel or oil leaks.
- e. The engine oil is at the proper level.
- f. The fuel strainer is drained.
6. a. Upon entering the airplane, all controls operate normally.
- b. All the required papers are in order and are in the airplane.
- c. The cabin door is closed and secured.

STARTING

When the engine is cold, prime three to five strokes after turning fuel valve to the proper tank. Push mixture control to full rich, carburetor heat off, and open throttle about one-eighth of an inch or until the intake of air at the carburetor can be heard when the engine is pulled through by hand. Engine should be pulled through at least four times.

Next turn the ignition switch to "Both" and with brakes set, have engine pulled through by hand or engage starter if installed. If the engine does not start in the first few revolutions, open the throttle while the engine is turning over with ignition on. When engine starts, reduce throttle.

If the above procedure does not start the engine, reprime and repeat process. Continue to load cylinders by priming or unload by turning over the engine with the throttle open.

If engine still does not start, check for malfunctioning of ignition or carburetor system.

When the engine is warm, do not prime, but turn ignition switch to "Both" before pulling propeller through. Engine should start after it has been rotated through four compression strokes. If turned over more than four times the engine will frequently "load up" after which it should be started with the throttle well advanced.

WARM-UP AND GROUND CHECK

As soon as the engine starts, the oil pressure should be checked. If no pressure is indicated within thirty seconds stop the engine and determine the trouble. In cold weather it will take a few seconds longer to get an oil pressure indication.

Warm up the engine at 800 to 1000 R.P.M., for not more than two minutes in warm weather, four minutes in cold weather. The magnetos should be checked at 1800 R.P.M., the drop not to exceed 100 R.P.M. The engine is warm enough for take-off when the throttle can be opened without engine faltering.

Carburetor heat should be checked during the warm-up to make sure the heat control operation is satisfactory and to clear out the engine if any ice has formed. It should also be checked in flight occasionally when outside air temperatures are between 20° and 70° to see if icing is occurring in the carburetor. In most cases when the engine loses speed without apparent cause, the use of carburetor heat will correct the condition.

TAKE-OFF, CLIMB, AND STALLS

The stabilizer adjustment should be set approximately in the neutral position for take-off. Fuel selector should be on the correct tank, carburetor heat off, mixture full rich. The flaps can be lowered if desired, but should be retracted as soon as climbing airspeed has been reached to achieve maximum rate of climb. The best rate of climb airspeed at gross load is 75 M.P.H. on both models of the Super Cub. At lighter weights, the best climbing airspeed will be reduced considerably.

The gross weight power off stalling speed with full flaps in the Super Cub 150 is 43 M.P.H.; with flaps up the stalling speed increases about 4 M.P.H.

CRUISING

The cruising speed of the Super Cubs at 75% of rated

engine power, at gross load under standard sea level conditions, is 100 M.P.H. for the model PA-18-95 and 115 M.P.H. for the model PA-18-150. Cruising airspeed and engine R.P.M. will depend on the propeller installed on the airplane.

Normally the 95 should be cruised at 2275 R.P.M. and the 150 at 2400 to 2450 R.P.M., but the 75% of power R.P.M. (low altitudes) can be determined as follows:

1. Fly the aircraft as near sea level as practicable at full throttle until maximum speed is reached. Note R.P.M. at top speed, level flight.

2. Reduce the maximum R.P.M. by 10% and cruise at 90% of full R.P.M. The correct cruising R.P.M. will result in a cruising airspeed of 100 M.P.H. with a fuel consumption of approximately 5 gallons per hour at full rich mixture on the 95, and an airspeed of 115 M.P.H. with a fuel consumption of approximately 9 gallons per hour on the 150. If the 150 is slowed down to the same cruising speed as the 95 or about 100 M.P.H., approximately the same amount of fuel, about 5 gallons per hour, will be used. See fuel consumption chart.

The metal propeller with which the Super Cub 150 is equipped as standard equipment is, unless specified otherwise, a 56 inch pitch propeller which favors take-off and climb rather than cruising speed. The use of this propeller reduces engine power output at normal cruising R.P.M. and therefore improves fuel economy considerably. At 2400 R.P.M. under standard conditions, the engine equipped with this propeller will be producing only about 60% of power rather than the 75% normally used. Fuel consumption will approximate 6.1 gallons per hour instead of the 7.7 gallons consumed at 75% of power.

For training and other purposes which do not require use of full power settings to obtain satisfactory performance, it is recommended that this propeller be operated, during take-off, climb, and cruise, at 2200 R.P.M. or less. This will still provide more performance than was formerly available in 65 H.P. trainers, and will reduce fuel consumption and engine wear very appreciably.

The fuel consumption chart should be consulted to determine most economical cruising R.P.M. for specific requirements.

A considerable saving in fuel usage can be affected in either model by judicious use of the mixture control during cruising flight. Unless icing conditions in the carburetor are severe, do not cruise with the carburetor heat on. Apply full carburetor heat only for a few seconds at intervals determined by icing severity.

APPROACH AND LANDING

During the approach, trim the plane with the stabilizer adjustment until no force is required on the stick to maintain a gliding speed of 70 M.P.H. Lower the flaps at an airspeed not to exceed 85 M.P.H. The mixture should be full rich, fuel valve on correct tank. The carburetor heat need not be used unless icing conditions prevail, but the engine should be cleared occasionally by opening the throttle.

During the landing roll the steerable tail wheel should be used for directional control, and brakes used as little as possible to avoid excessive brake and tire wear.

To stop the engine after landing, pull the mixture control full out to idle-cut off. After the engine stops, turn the ignition and master switch (if any) off.

WEIGHT AND BALANCE

For weight and balance data, see the weight and balance sheet which gives the exact weight of the airplane and permissible center of gravity conditions.

SECTION IV

PERFORMANCE CHART

Fuel Consumption 21

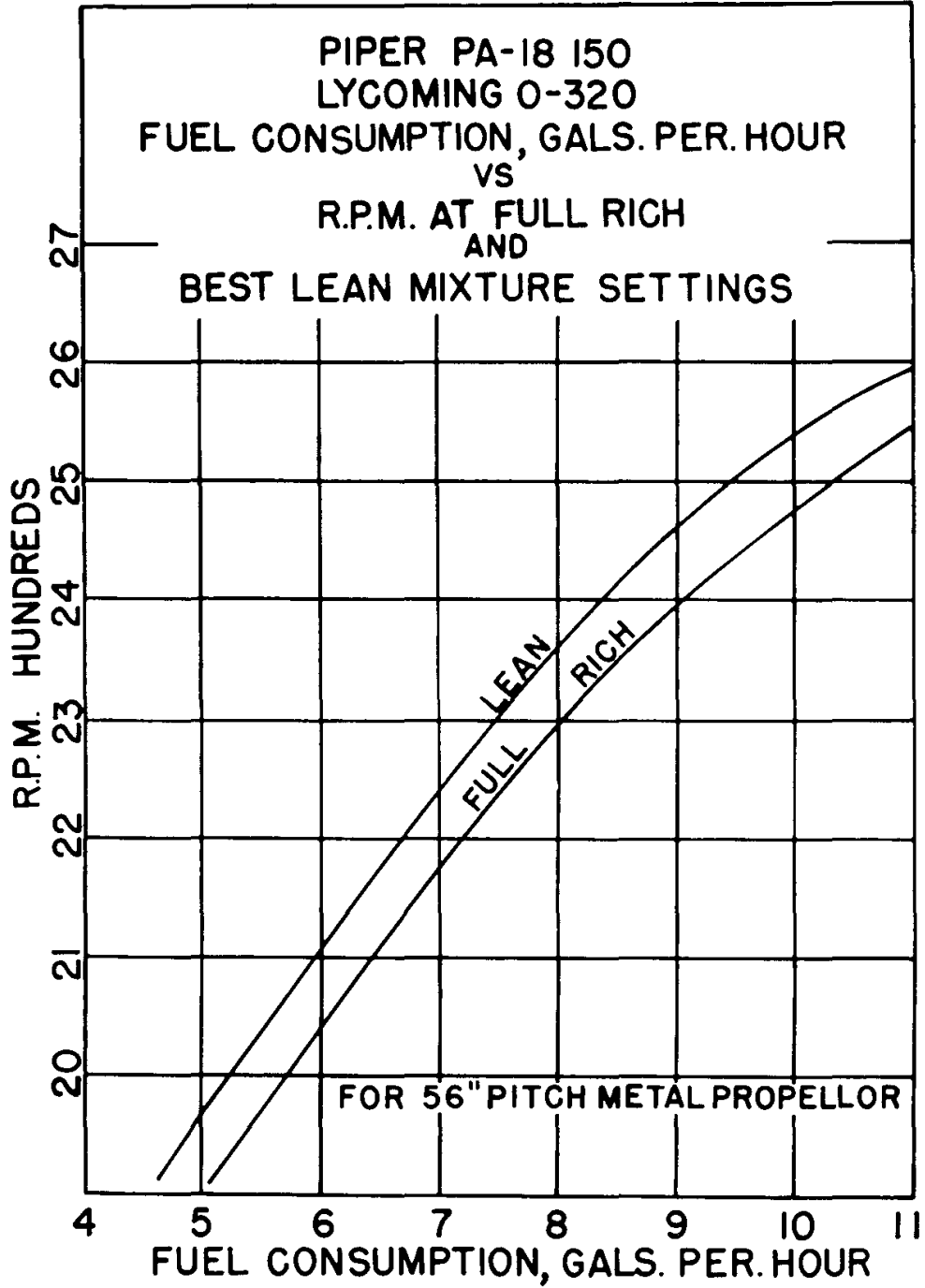

SECTION V

GENERAL MAINTENANCE

Tire Inflation	23
Battery Service	23
Care of Windshield and Windows	23
Fuel and Oil Requirements	24
Carburetor Air Filter	24
Brake Service	25
Landing Gear Service	27
Leveling and Rigging	27
Serial Number Plate	30

SECTION V

GENERAL MAINTENANCE

TIRE INFLATION

For maximum tire service, keep the tires inflated to the proper pressure, which is 18 pounds on the Super Cub. Reverse the tires on the wheels, if necessary, to produce even wear.

BATTERY SERVICE

A 12-volt 33-ampere hour battery is installed with the electrical equipment as optional equipment. The battery should be checked frequently for proper fluid level. Do not fill the battery above the baffle plates. Be sure all connections are clean and tight. If battery is not up to proper charge, recharge, starting with a charging rate of four amps and finishing with two amps. If a quick charge is desired for the battery, be sure master switch is off while charging.

CARE OF WINDSHIELD AND WINDOWS

The windshield and windows are made of plexiglas and a certain amount of care is required to keep them clean and clear. The following procedure is suggested:

1. Wash with clean water and dislodge excess dirt, mud, etc. with your hand.
2. Wash with mild soap and warm water. Use a soft cloth or sponge. (Do not rub.)
3. Remove oil, grease or sealing compounds with a cloth soaked in kerosene.

NOTE

Do not use gasoline, alcohol, benzene, carbon

tetrachloride, lacque thinner, or window cleaning sprays.

4. After cleaning, apply a thin coat of hard polishing wax. Rub lightly with soft dry cloth.

5. A severe scratch or mar can be removed by using jewelers rouge to rub out scratch, smooth on both sides and apply wax.

FUEL AND OIL REQUIREMENTS

Aviation Grade 80/87 octane gasoline should be used in the Super Cub. The fuel gauge glass should be cleaned occasionally so that the fuel level indicator will always be readily seen. To clean or replace the fuel gauges, first remove lower wing butt fairings. Pinch the rubber line to the lower gauge fitting so that fuel cannot drain from the tank. Then remove the fuel gauges by pulling the fittings from the connecting rubber tubes.

The oil capacity of the O-320 engine is 8 quarts, the C-90-8F or 12F is 5 quarts. It is recommended the engine oil be changed every 50 hours, or sooner under adverse conditions. Minimum safe quantity of oil is 2 quarts. The following grades are recommended for the specified temperatures:

Temperatures above 60° F	SAE 50
Temperatures between 30° F to 90° F	SAE 40
Temperatures between 0° F to 70° F	SAE 30
Temperatures below 10° F	SAE 20

CARBURETOR AIR FILTER

1. Visual Inspection

A visual inspection of the paper cartridge should be made at intervals not exceeding eight (8) hours of operation or at any time after the filter has been subjected to severe dust

conditions. This inspection should be made to determine if there has been a rupture of the paper cartridge, damage to the outer screen or end seals, or blockage of the air flow due to leaves, paper, etc.

2. Cleaning

Remove cartridge and clean by tapping against a hard surface to remove grit, sand and dirt. Do not wash or blow out with an air hose.

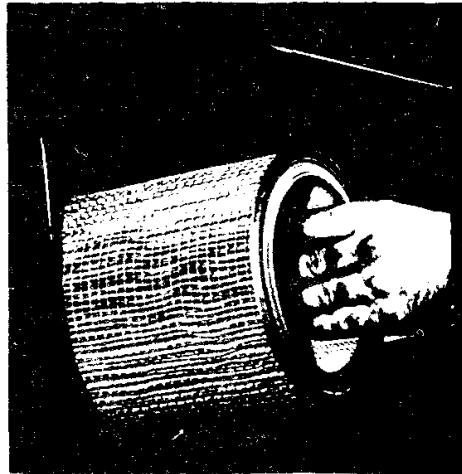

3. Replacement

If the present cartridge is found to be in good condition and is not obstructed after being properly cleaned (see paragraphs 1 and 2), the following check should be made:

- a. Operate engine to static R.P.M. at full throttle and note R.P.M.
- b. Remove filter cartridge and repeat operation in paragraph 3a.

If an increase of 50 R.P.M. or greater is noted, a new cartridge should be installed.

BRAKE SERVICE

The brake system is filled with Univis #40 (petroleum base) hydraulic brake fluid. This should be checked at every 100 hour inspection, and replenished if necessary.

Do not use or mix mineral or vegetable base brake fluids when refilling system. When it is necessary to refill brake system, or when the brakes seem spongy, probably due to air in the lines, the following procedures are to be followed:

1. To fill the brake system, remove filler plugs on right wheel brake master cylinder. Remove bleeder screw from tee on right wheel brake unit and attach line from brake fluid pressure can. Fill system until master cylinders are full.

Repeat procedure for left wheel brake. If pressure can is not available, an open can with line attached may be used, providing can is held higher than master cylinders. When two master cylinders are full, replace filler plugs and bleeder screws. Check brakes for satisfactory operation.

2. Air in the brake lines causes faulty operation which can be corrected by bleeding the brake system as follows:

- a. Check entire system for breaks or leaks.
- b. Remove bleeder screw from particular brake unit and insert bleeder hose. Place free end in a clean receptacle.
- c. Remove filler plug from master cylinders of the particular brake which is being bled.
- d. Fill master cylinders with Univis #40 hydraulic fluid and keep cylinders full during bleeding process.
- e. Work the brake pedal rapidly to force fluid through bleeder hose into receptacle. Pinch hose shut during return of pedal to off position. Release pressure on hose, and push pedal on rapidly again. While fluid is flowing, restrict bleeder hose and allow brake pedal to return slowly to off position. Continue this process until no more air bubbles are observed coming through bleeder hose. The system is then properly bled.
- f. Replace bleeder screw; check to see that master cylinders are full, and replace filler plugs. Check brakes for satisfactory operation.

No adjustment of the brake clearances is necessary on the Super Cub brakes. If, after extended service, the brakes become less effective, the brake segments can be easily replaced as follows: Remove the wheels to expose the brake shoe blocks, then slip blocks from their retainer clips with a screwdriver. Replace with new brake segments and reinstall the wheels.

Wheels are quickly removed by taking off the hub caps, removing the cotter pin from the hub nut and unscrewing the nut. The wheel can then be pulled freely from the axle.

Tires are dismounted from the wheels as follows:

1. Deflate tube.
2. Remove safety clevis pin from outer wheel flange.
3. Extract lock ring which holds the outer flange in place.

4. Slide flange, tire and tube from the hub.

LANDING GEAR SERVICE

The landing gear shock cords, which are enclosed in streamlined shock cord covers, should be inspected regularly for signs of wear. Shock struts and landing gear hinge bolts should be kept properly lubricated with light grease or oil.

LEVELING AND RIGGING

The airplane should be leveled as follows:

Suspend a plumb bob on a string from the hole in the rear of the upper door frame channel. The hole is exposed by removing the wing root fairing at this point. The airplane will be leveled longitudinally and laterally when this plumb bob hangs directly over a depression in the horizontal door frame tube, about one inch ahead of its rearward end.

Lateral leveling: Place jacks or blocks under the inside portion of the axles, adjusting them until the plumb bob is roughly in line laterally with the mark on the door frame.

Longitudinal leveling: Support the tail on an adjustable jack or stand so that the airplane is approximately in level flight. Adjust the jack until the plumb bob is in line longitudinally with the reference mark.

Next readjust the lateral leveling jacks until the plumb bob hangs directly over the designated mark. The airplane is then leveled on both axes.

Rigging of the aircraft is done as follows:

1. Dihedral angle: Place a block $3/8$ " high on one end of a 30" level. Hold the level between the jury strut and the main strut attachments under the front spar with spacer block outboard. When the bubble is centered, the front spars have an angle of 45 minutes off level.

Normally the correct dihedral will be obtained when about seven threads on the lift strut adjustment forks are exposed. (A maximum extension of 15 threads is permissible). If proper

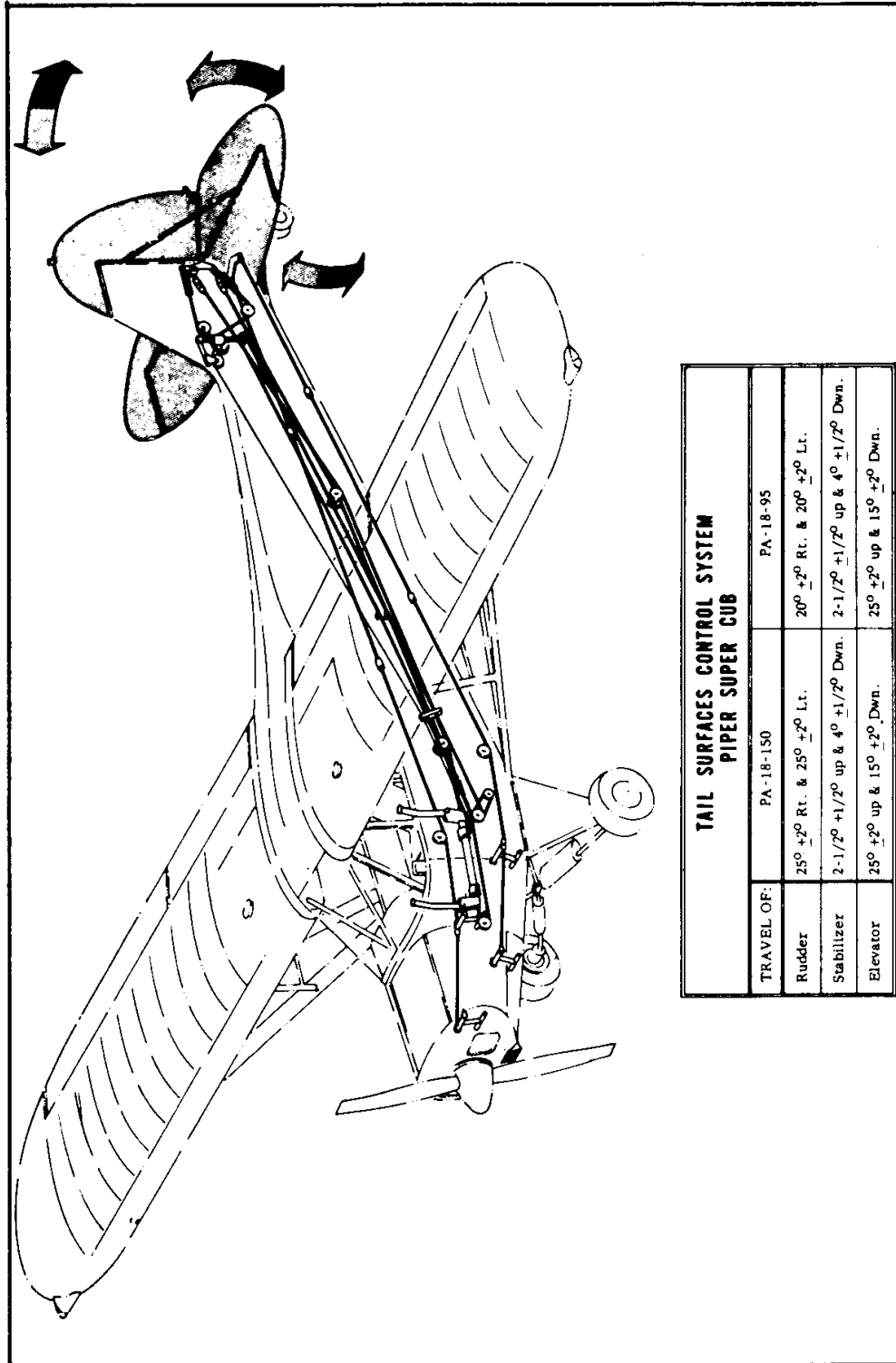

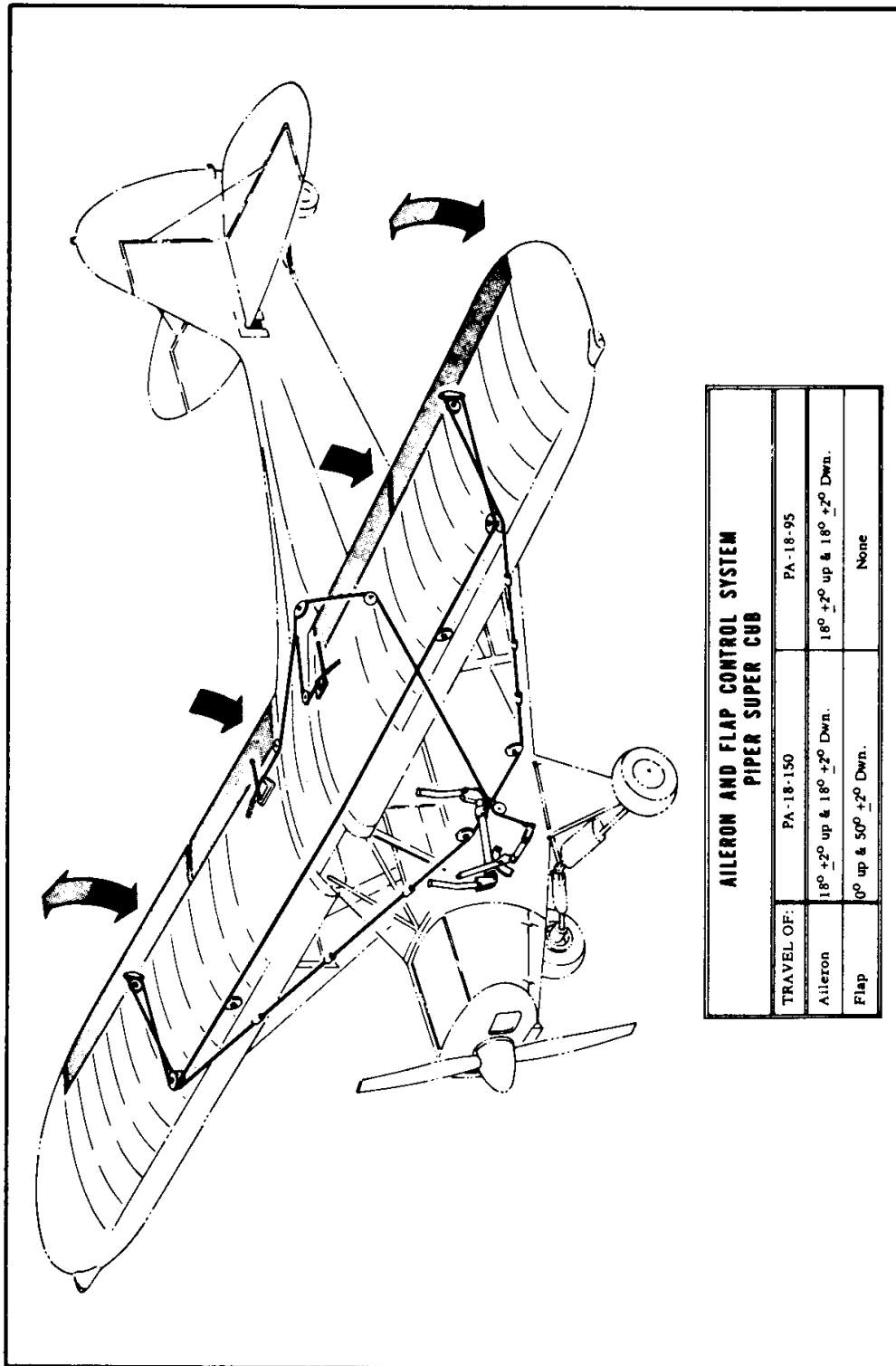

AILERON AND FLAP CONTROL SYSTEM PIPER SUPER CUB	
TRAVEL OF:	PA-18-150 PA-18-95
Aileron	18° +2° up & 18° +2° Dwn. 18° +2° up & 18° +2° Dwn.
Flap	0° up & 50° +2° Dwn. None

rigging does not result from this procedure, check the fuselage for lateral leveling by holding a level between the front landing gear bolt heads, using this means to level the fuselage laterally, rather than the plumb bob. Then recheck for equal and proper dihedral of the wings.

2. Wash out: Place a 3/8" spacer block on top of a 30 inch level at one end. Working on the outboard aileron rib, hold the level fore and aft with the spacer block at the rear and the front end of the level under the front spar. The correct wash out will exist when the bubble is centered. Adjust the rear struts in or out to obtain this condition.

3. Tail Assembly: With the airplane in level position, the stabilizer should be leveled at their rear spars by adjusting the tail brace wires. The elevator hinge line should be straight from tip to tip. The fin should be vertical at the rudder post.

SERIAL NUMBER PLATE

The serial number plate is located under the front seat on the floor. The serial number of the airplane should always be used when referring to the airplane in service or warranty matters.